

4

3

2

1

THIS DRAWING IS UNPUBLISHED.
DIFFUSION RESEINTE AMP

RELEASED FOR PUBLICATION

.19

LOC DIST
FH 00

REVISIONS

© COPYRIGHT 1997

BY AMP INCORPORATED. ALL RIGHTS RESERVED.
TOUS DROITS RESERVES

P	LTR REV	DESCRIPTION MODIFICATIONS	DATE	DWN DESS.	APVD APP.
	A	EQ00-0261-08	11-Jun-08	EN	LR

Cable ou tube ø31 à 35.99
Cable or tube 31DIA to 35.99
Cable o tubo ø31 a 35.99

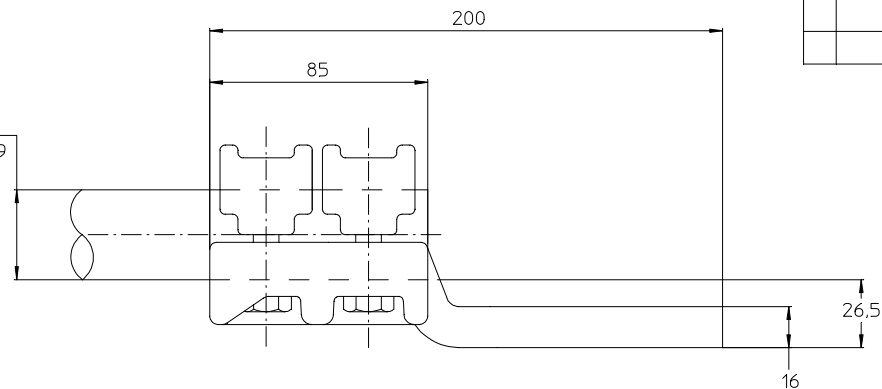

37 Nm { 8 Boulons ø10 acier inox A2
8 Bolts 10DIA stainless steel A2
8 Tornillos ø10 acero inoxidable A2

4 Troux ø18
4 Holes 18 DIA
4 Agujeros ø18

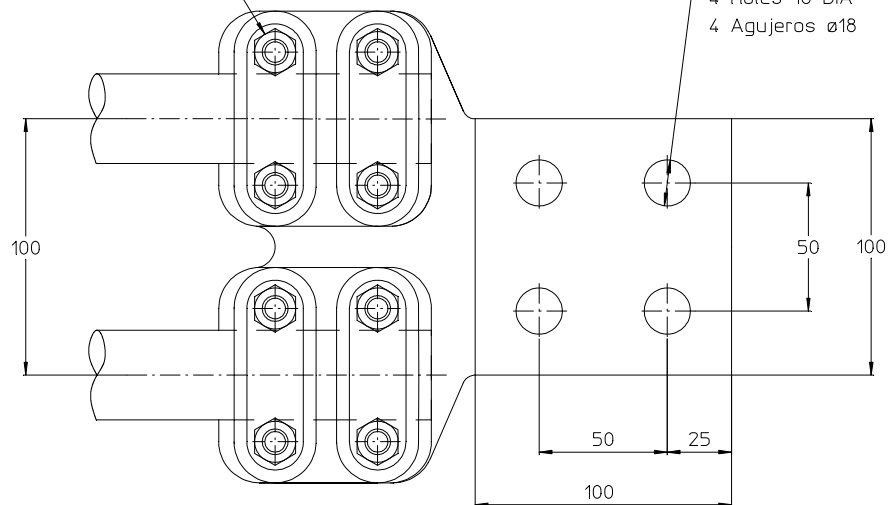

<small>THIS DRAWING IS A CONTROLLED DOCUMENT FOR AMP INCORPORATED. IT IS SUBJECT TO CHANGE AND THE CONTROLLING ENGINEERING ORGANIZATION SHOULD BE CONTACTED FOR THE LATEST REVISION. CE PLAN EST UN DOCUMENT CONTRÔLÉ PAR AMP INCORPORATED. IL EST SUSCEPTIBLE D'ÊTRE REVISÉ, CONTACTER LE SERVICE TECHNIQUE D'AMP SIMEL POUR OBTENIR LA DERNIÈRE REVISION.</small>		DWN /DESSINE NIVOIS 11-Jun-08			SIMEL PRODUCTS	
DIMENSIONS: mm		CHK /VERIFIE GODARD 11-Jun-08	APVD /APPROUVE ROYER		NAME TITRE CD 82 F 35 E100 100 C559	
		TOLERANCES UNLESS OTHERWISE SPECIFIED PER TOLERANCES NON SPECIFIEES SELON : -		PRODUCT SPEC SPEC. PRODUIT 02BFC0031		SIZE FORMAT A3
MATERIAL MATIERE -		FINISH FINITION -		APPLICATION SPEC SPEC. APPLICATION -		CAGE CODE 00779
		WEIGHT MASSE APPROX. 2.1 KG		DRAWING NO NO PLAN C=2062370		SCALE ECHELLE 1/2
		CUSTOMER DWG / PLAN CLIENT		UNIQUEMENT POUR REFERENCE		SHEET FEUILLE 1 OF 1 DE 1
						REV A

ITEM: